

# **IntesisBox**®

## DK-AC-MBS-1

v.0.4

MODBUS RTU (RS-485) Interface for Daikin air conditioners.  
Compatible with Domestic line models

## User Manual

Issue Date: 14/03/2013

Order Codes:

**DK-AC-MBS-1:** Modbus RTU Interface for Daikin air conditioners

**© Intesis Software S.L. 2012. All Rights Reserved.**

Information in this document is subject to change without notice. No part of this publication may be reproduced, stored in a retrieval system or transmitted in any form or any means electronic or mechanical, including photocopying and recording for any purpose other than the purchaser's personal use without the written permission of Intesis Software S.L.

Intesis Software S.L.  
Milà i Fontanals, 1 bis  
08700 Igualada  
Spain

**TRADEMARKS**

All trademarks and tradenames used in this document are acknowledged to be the copyright of their respective holders.

INDEX

- 1. Presentation ..... 4
- 2. Connection ..... 5
  - 2.1 Connect to the AC indoor unit ..... 5
  - 2.2 Connection to the RS485 bus ..... 5
- 3. Modbus Interface Specification ..... 6
  - 3.1 Modbus physical layer ..... 6
  - 3.2 Modbus Registers ..... 6
    - 3.2.1 Control and status registers ..... 6
    - 3.2.2 Configuration Registers ..... 7
  - 3.3 DIP-switch Configuration Interface ..... 8
  - 3.4 Implemented Functions ..... 9
  - 3.5 Device LED indicator ..... 10
  - 3.6 RS485 bus. Termination resistors and Fail Safe Biasing mechanism ..... 10
- 4. Specifications ..... 12
- 5. List of supported AC Unit Types ..... 12
  - 5.1 Error Codes ..... 13

## 1. Presentation



The DK-AC-MBS-1 interface allows a complete and natural integration of **Daikin** air conditioners into Modbus RTU (RS-485) networks.

Compatible with all models of Domestic and Mr.Slim line (section 5).

- Reduced dimensions. 93 x 53 x 58 mm.
- Quick and easy installation.  
*Mountable on DIN rail, wall, or even inside the indoor unit in some models of AC.*
- External power not required.
- Direct connection to MODBUS RTU (RS-485) networks.  
*DK-AC-MBS-1 is a Modbus slave device.*
- Direct connection to the AC indoor unit.  
*The cable for this connection is also supplied.*
- Configuration from both on-board DIP-switches and MODBUS RTU.
- Total Control and Supervision.
- Real states of the AC unit's internal variables.
- Allows using simultaneously the IR remote control and MODBUS RTU.

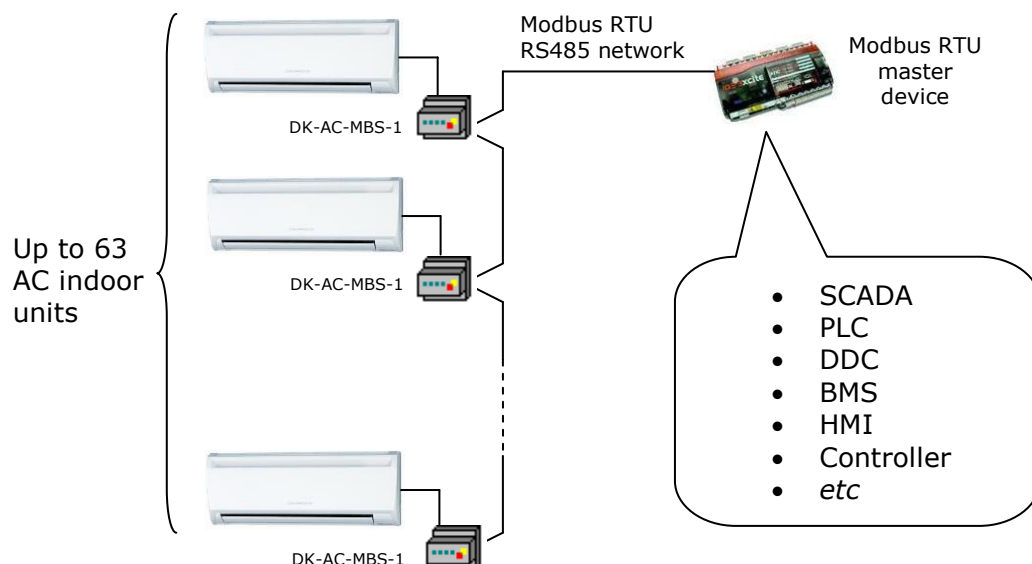

## 2. Connection

The interface comes with cable + connectors for direct connection to the AC indoor unit, and with a plug-in terminal block of 2 poles for connection to a Modbus RTU RS-485 network.

### 2.1 Connect to the AC indoor unit

To connect the DK-AC-MBS-1 interface to the AC indoor unit follow these steps:

Disconnect mains power from the AC unit. Open the front cover of the indoor unit in order to have access to the electronic circuit. In the electronic circuit locate the socket connector marked as:

**S21** in Domestic line models

Using the cable that comes with the interface, insert one of its connectors, the biggest one, into the socket of the DK-AC-MBS-1, and the other connector, the one installed in the largest uncovered part, to the socket **S21** of the AC unit's electronic circuit. Close the AC indoor unit's front cover again.

Do not modify the length of the cable supplied with the interface, it may affect to the correct operation of the interface.

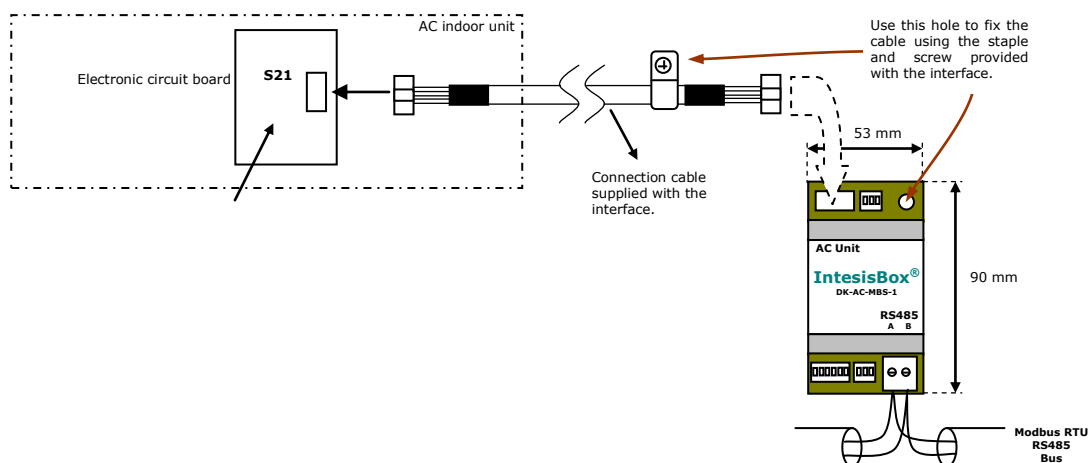

### 2.2 Connection to the RS485 bus

Connect the RS485 bus wires to the plug-in terminal block (the one of two poles) of DK-AC-MBS-1, respect the polarity on this connection (A+ and B-). Respect the maximum distance of 1.200 meters for the bus, no loop or star topologies are allowed for RS485 bus, a terminator resistor of 120 must be present at each end of the bus to avoid signal reflections and also a fail-safe biasing mechanism (see section 3.6 for more details).

### 3. Modbus Interface Specification

#### 3.1 Modbus physical layer

DK-AC-MBS-1 implements a MODBUS RTU (slave) interface, to be connected to an RS-485 line. It performs an 8N2 (8N1-compatible) communication (8 data bits, no parity and 1 or 2 stop bit) with several available baudrates (2400 bps, 9600 bps -default-, 19200 bps and 57600 bps).

#### 3.2 Modbus Registers

All registers are of type "16-bit unsigned Holding Register", in standard ModBus' big endian notation.

##### 3.2.1 Control and status registers

Register Address (protocol address)	Register Address (PLC address)	R/W	Description
0	1	R/W	AC unit On/Off <ul style="list-style-type: none"> <li>▪ 0: Off</li> <li>▪ 1: On</li> </ul>
1	2	R/W	AC unit Mode <sup>1</sup> <ul style="list-style-type: none"> <li>▪ 0: Auto</li> <li>▪ 1: Heat</li> <li>▪ 2: Dry</li> <li>▪ 3: Fan</li> <li>▪ 4: Cool</li> </ul>
2	3	R/W	AC unit Fan Speed <sup>1</sup> <ul style="list-style-type: none"> <li>▪ 0: Auto</li> <li>▪ 1: Low</li> <li>▪ 2: Mid-1</li> <li>▪ 3: Mid-2</li> <li>▪ 4: High</li> </ul>
3	4	R/W	AC unit Up/Down Vane Position <sup>1</sup> <ul style="list-style-type: none"> <li>▪ 0: Auto</li> <li>▪ 10: Swing</li> </ul>
4	5	R/W	AC unit Temperature Setpoint <sup>1,2</sup> <ul style="list-style-type: none"> <li>▪ 16..31 (°C)</li> <li>▪ 61..90 (°F)</li> </ul>
6	7	R/W	Window Contact <ul style="list-style-type: none"> <li>▪ 0: Closed</li> <li>▪ 1: Open</li> </ul>
7	8	R/W	DK-AC-MBS-1 Control disablement <sup>3</sup> <ul style="list-style-type: none"> <li>▪ 0: AC control enabled</li> <li>▪ 1: AC control disabled</li> </ul>
8	9	R/W	AC's Remote Control Disablement <sup>3</sup> <ul style="list-style-type: none"> <li>▪ 0: Remote Control enabled</li> <li>▪ 1: Remote Control disabled</li> </ul>

<sup>1</sup> See Section 5 for detail on indoor unit model differences and function availability

<sup>2</sup> Magnitude for this register can be adjusted to Celsius (default) or Fahrenheit through DIP switch P5

<sup>3</sup> This value is stored in non-volatile memory

Register Address (protocol address)	Register Address (PLC address)	R/W	Description
9	10	R/W	AC unit Operation Time <sup>4</sup> <ul style="list-style-type: none"> <li>0..65535 (hours). Counts the time the AC unit is in "On" state.</li> </ul>
10	11	R	AC unit Alarm Status <ul style="list-style-type: none"> <li>0: No alarm condition</li> <li>1: Alarm condition</li> </ul>
11	12	R	Error Code. Details in section 5.1
26	27	R/W	AC unit Left/Right Vane Position <sup>1</sup> <ul style="list-style-type: none"> <li>0: Auto</li> <li>10: Swing</li> </ul>
28	29	R/W	AC Humidification Value <ul style="list-style-type: none"> <li>0: Off</li> <li>1: Low Humidification</li> <li>2: Medium Humidification</li> <li>3: High Humidification</li> <li>10: Continuous</li> </ul>

### 3.2.2 Configuration Registers

Register Address (protocol address)	Register Address (PLC address)	R/W	Description
13	14	R/W	"Open Window" switch-off timeout <sup>5, 4</sup> <ul style="list-style-type: none"> <li>0..30 (minutes)</li> <li>Factory setting: 30 (minutes)</li> </ul>
14	15	R	Modbus RTU baud-rate <sup>6, 4</sup> <ul style="list-style-type: none"> <li>2400 bps</li> <li>4800 bps</li> <li>9600 bps</li> <li>19200 bps</li> <li>Factory setting: (9600 bps)</li> </ul>
15	16	R	Device's Modbus slave address <sup>6, 3</sup> <ul style="list-style-type: none"> <li>1..63</li> <li>Factory setting: 0 (no address / configured at DIP-switch)</li> </ul>
21	22	R	Max number of fan speeds <ul style="list-style-type: none"> <li>Value is always 5</li> </ul>
49	50	R	Device definition: <ul style="list-style-type: none"> <li>0x700 (DK-AC-MBS-1)</li> </ul>
50	51	R	Software version

<sup>4</sup> This value is stored in non-volatile memory

<sup>5</sup> Once window contact is open, a count-down to switch off the AC Unit will start from this configured value

<sup>6</sup> This value is set-up from device's on-board DIP-switches. See Section 3.3

### 3.3 DIP-switch Configuration Interface

All configuration values on DK-AC-MBS-1 can be written and read from ModBus interface. Though, some of them can also be setup from its on-board DIP-switch interface.

They are DIP-switches P5, P6\* and P7 on the device, in the following location:

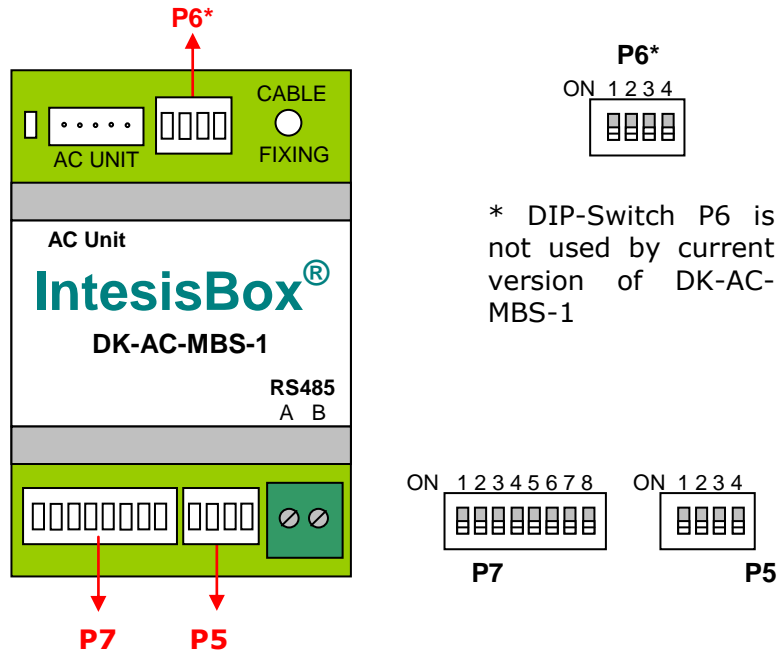

The following table applies for configuration of the interface through these DIP-switches:

**P7** – Modbus protocol: Slave address and baudrate

Add	Switches								Add	Switches								Add	Switches								Add	Switches							
	1	2	3	4	5	6	7	8		1	2	3	4	5	6	7	8		1	2	3	4	5	6	7	8		1	2	3	4	5	6	7	8
0	↓	↓	↓	↓	↓	↓	x	x	16	↓	↓	↓	↓	↑	↓	x	x	32	↓	↓	↓	↓	↓	↑	x	x	48	↓	↓	↓	↓	↑	↑	x	x
1*	↑	↓	↓	↓	↓	↓	x	x	17	↑	↓	↓	↓	↑	↓	x	x	33	↑	↓	↓	↓	↓	↑	x	x	49	↑	↓	↓	↓	↑	↑	x	x
2	↓	↑	↓	↓	↓	↓	x	x	18	↓	↑	↓	↓	↑	↓	x	x	34	↓	↑	↓	↓	↓	↑	x	x	50	↓	↑	↓	↓	↑	↑	x	x
3	↑	↑	↓	↓	↓	↓	x	x	19	↑	↑	↓	↓	↑	↓	x	x	35	↑	↑	↓	↓	↓	↑	x	x	51	↑	↑	↓	↓	↑	↑	x	x
4	↓	↓	↑	↓	↓	↓	x	x	20	↓	↓	↑	↓	↑	↓	x	x	36	↓	↓	↑	↓	↓	↑	x	x	52	↓	↓	↑	↓	↑	↑	x	x
5	↑	↓	↑	↓	↓	↓	x	x	21	↑	↓	↑	↓	↑	↓	x	x	37	↑	↓	↑	↓	↓	↑	x	x	53	↑	↓	↑	↓	↑	↑	x	x
6	↓	↑	↑	↓	↓	↓	x	x	22	↓	↑	↑	↓	↑	↓	x	x	38	↓	↑	↑	↓	↓	↑	x	x	54	↓	↑	↑	↓	↑	↑	x	x
7	↑	↑	↑	↓	↓	↓	x	x	23	↑	↑	↑	↓	↑	↓	x	x	39	↑	↑	↑	↓	↓	↑	x	x	55	↑	↑	↑	↓	↑	↑	x	x
8	↓	↓	↓	↑	↓	↓	x	x	24	↓	↓	↓	↑	↑	↓	x	x	40	↓	↓	↓	↑	↓	↑	x	x	56	↓	↓	↓	↑	↑	↑	x	x
9	↑	↓	↓	↑	↓	↓	x	x	25	↑	↓	↓	↑	↑	↓	x	x	41	↑	↓	↓	↑	↓	↑	x	x	57	↑	↓	↓	↑	↑	↑	x	x
10	↓	↑	↓	↑	↓	↓	x	x	26	↓	↑	↓	↑	↑	↓	x	x	42	↓	↑	↓	↑	↓	↑	x	x	58	↓	↑	↓	↑	↑	↑	x	x
11	↑	↑	↓	↑	↓	↓	x	x	27	↑	↑	↓	↑	↑	↓	x	x	43	↑	↑	↓	↑	↓	↑	x	x	59	↑	↑	↓	↑	↑	↑	x	x
12	↓	↓	↑	↑	↓	↓	x	x	28	↓	↓	↑	↑	↑	↓	x	x	44	↓	↓	↑	↑	↓	↑	x	x	60	↓	↓	↑	↑	↑	↑	x	x
13	↑	↓	↑	↑	↓	↓	x	x	29	↑	↓	↑	↑	↑	↓	x	x	45	↑	↓	↑	↑	↓	↑	x	x	61	↑	↓	↑	↑	↑	↑	x	x
14	↓	↑	↑	↑	↓	↓	x	x	30	↓	↑	↑	↑	↑	↓	x	x	46	↓	↑	↑	↑	↓	↑	x	x	62	↓	↑	↑	↑	↑	↑	x	x
15	↑	↑	↑	↑	↓	↓	x	x	31	↑	↑	↑	↑	↑	↓	x	x	47	↑	↑	↑	↑	↓	↑	x	x	63	↑	↑	↑	↑	↑	↑	x	x

**Table 3.1** P7: Modbus Slave address

\* Default value

Binary value b <sub>0</sub> ...b <sub>8</sub>	Decimal value	Switches 1 2 3 4 5 6 7 8	Description
xxxxxx00	0	x x x x x x ↓ ↓	2400bps
xxxxxx10	1	x x x x x x ↑ ↓	4800bps
xxxxxx01	2	x x x x x x ↓ ↑	9600bps (- default value)
xxxxxx11	3	x x x x x x ↑ ↑	19200bps

**Table 3.2** P7: Modbus baud rate

**P5** – Other: Degrees/Decidegree (x10), temperature magnitude (°C/°F) and EIA485 termination resistor

Binary value b <sub>0</sub> ...b <sub>4</sub>	Decimal value	Switches 1 2 3 4	Description
0xxx	0	↓ x x x	Temperature values in Modbus register are represented in degrees (x1) (default value)
1xxx	1	↑ x x x	Temperature values in Modbus register are represented in decidegrees (x10)
x0xx	0	x ↓ x x	Temperature values in Modbus register are represented in Celsius degrees (default value)
x1xx	1	x ↑ x x	Temperature values in Modbus register are represented in Fahrenheit degrees
xxx0	0	x x x ↓	EIA485 bus without termination resistor (default value)
xxx1	1	x x x ↑	Internal termination resistor of 120Ω connected to EIA485 bus**

**Table 3.3** Temperature and termination configuration

### 3.4 Implemented Functions

DK-AC-MBS-1 implements the following standard MODBUS functions:

- 3: Read Holding Registers
- 4: Read Input Registers
- 6: Write Single Register
- 16: Write Multiple Registers (Although this function is allowed, the interface does not allow write operations on more than 1 register with the same request, this means that length field should always be 1 when using this function for writes)

\*\* Only in the interfaces connected at both ends of the bus must be activated the termination resistor. More information in section 3.6

### 3.5 Device LED indicator

The device includes a LED indicator to signal its different possible operational states. In the following table are presented the different indications it can perform and its meaning.

Device status	LED indication	ON / OFF Period	Meaning
On power-up	LED pulse	ON for 5 seconds / OFF after	Device reset / power-up
During normal operation	LED flashing	200ms ON / 2s OFF	Device correctly configured and working
During normal operation	LED OFF	OFF continuously	No Modbus slave address configured
During normal operation	LED blinking	200ms ON / 200ms OFF	Communication Error with the AC unit

### 3.6 RS485 bus. Termination resistors and Fail Safe Biasing mechanism

RS485 bus requires a 120Ω terminator resistor at each end of the bus to avoid signal reflections.

In order to prevent fail status detections by the receivers "*listening*" the bus when all the transmitters outputs are in three-state (high impedance), it is also required a fail-safe biasing mechanism. This mechanism provides a safe status (a correct voltage level) in the bus when all the transmitters' outputs are in three-state.

The DK-AC-MBS-1 device includes an on-board terminator resistor of 120Ω that can be connected to the RS485 bus by using DIP-switch P5 (see below).

A fail safe biasing circuit has also been included in the board of DK-AC-MBS-1, it can be connected to the RS485 bus by placing the internal jumpers JP2 and JP3 (see details below).

This fail safe biasing of the RS485 bus must only be supplied by one of the devices connected to the bus. As this fail safe biasing circuit also provides a termination resistance, only one of both must be selected in the DK-AC-MBS-1 device, fail safe biasing (*jumpers JP2 and JP3 placed*) or terminator resistor (*DIP-switch P5 position 4 to ON*).

The device providing fail safe biasing or terminator resistor should be the one connected at one end of the bus. At the other end of the bus, if there is also a DK-AC-MBS-1 device, select the 120Ω terminator resistor through DIP-switch P5, or if there is a master device not providing internal 120Ω terminator resistor, connect an external 120Ω resistor in the bus terminal block connection of such master device.

*Some Modbus RTU RS485 master devices can provide also internal 120Ω terminator resistor and/or fail safe biasing (consult the technical documentation of the master device connected to the RS485 network in every case).*

Location of jumpers and DIP-switches for RS485 bus Termination resistor or Fail Safe Biasing selection:

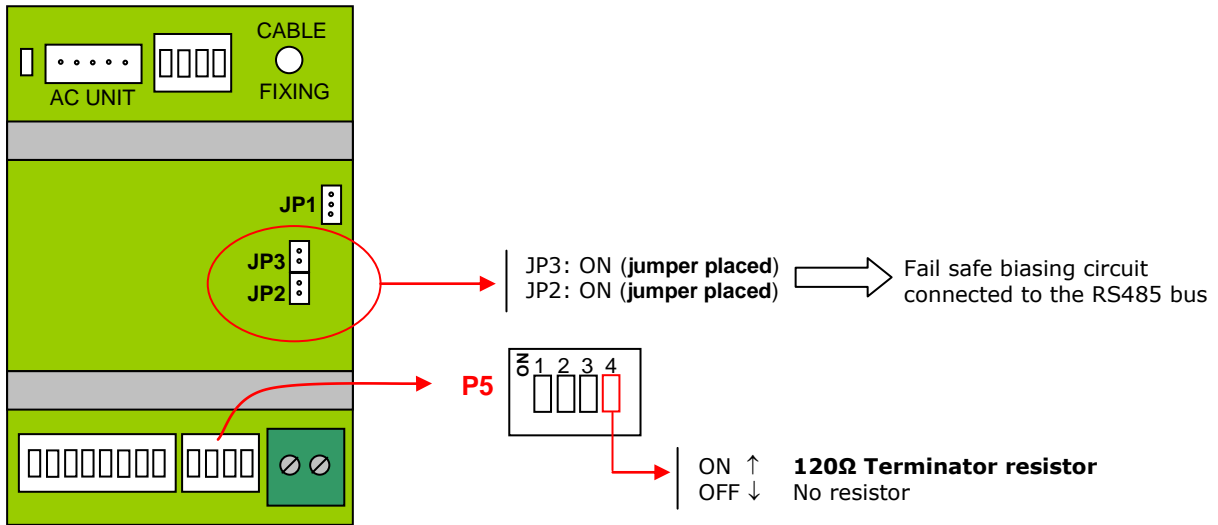

To access to internal jumpers JP2 and JP3, extract the top cover of the interface inserting a small screw-driver or clip in the holes located at both sides of the cover.

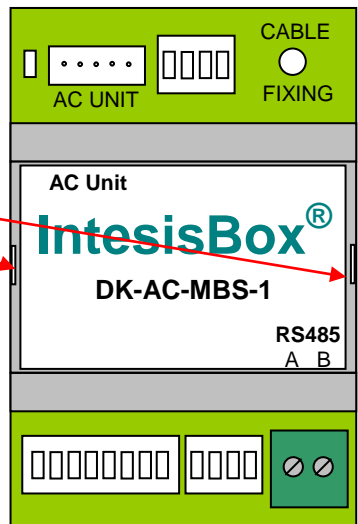

## 4. Specifications

Dimensions:	93 x 53 x 58 mm
Weight:	85 g
Operating Temperature:	-40 . . . 85°C
Stock Temperature:	-40 . . . 85°C
Operating Humidity:	<95% RH, non-condensing
Stock Humidity:	<95% RH, non-condensing
Isolation voltage:	1000 VDC
Isolation resistance:	1000 MΩ
Modbus Media:	Compatible with Modbus RTU - RS485 networks

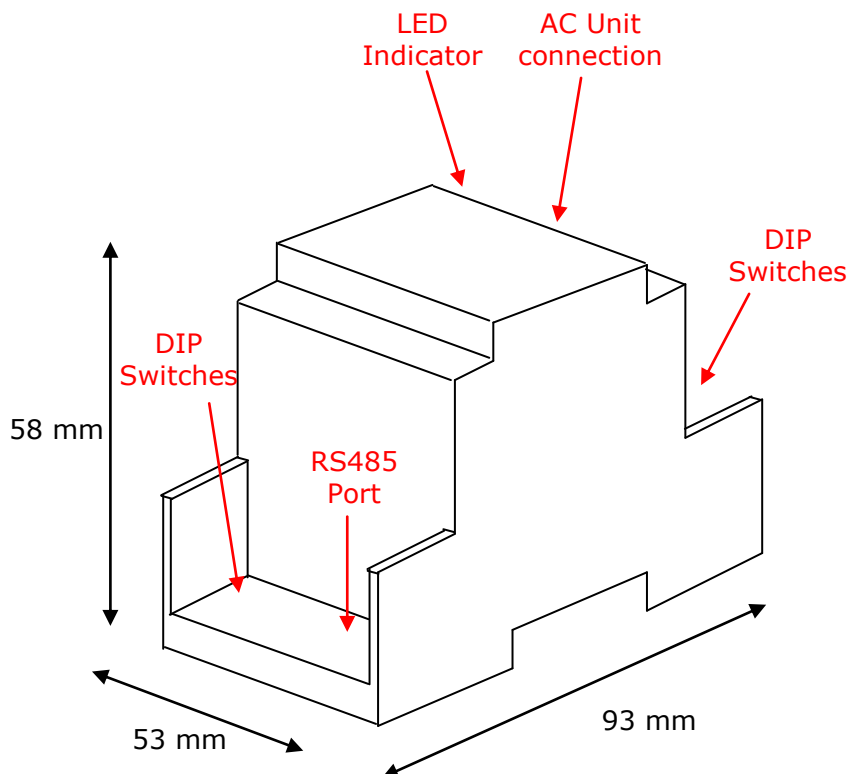

## 5. List of supported AC Unit Types

A list of Daikin indoor unit model references compatible with DK-AC-MBS-1 and their available features can be found in:

[http://www.intesis.com/pdf/IntesisBox\\_DK-AC-xxx-1\\_AC\\_Compatibility.pdf](http://www.intesis.com/pdf/IntesisBox_DK-AC-xxx-1_AC_Compatibility.pdf)

## 5.1 Error Codes

Error Code	Error in Remote Controller	Error category	Error Description
0	N/A	DK-AC-MBS-1	No active error
17	A0	Indoor Unit	External protection devices activated
18	A1		Indoor unit PCB assembly failure
19	A2		Interlock error for fan
20	A3		Drain level system error
21	A4		Temperature of heat exchanger (1) error
22	A5		Temperature of heat exchanger (2) error
23	A6		Fan motor locked, overload, over current
24	A7		Swing flap motor error
25	A8		Overcurrent of AC input
26	A9		Electronic expansion valve drive error
27	AA		Heater overheat
28	AH		Dust collector error / No-maintenance filter error
30	AJ		Capacity setting error (indoor)
31	AE		Shortage of water supply
32	AF		Malfunctions of a humidifier system (water leaking)
33	C0		Malfunctions in a sensor system
36	C3		Sensor system of drain water error
37	C4		Heat exchanger (1) (Liquid pipe) thermistor system error
38	C5		Heat exchanger (1) (Gas pipe) thermistor system error
39	C6		Sensor system error of fan motor locked, overload
40	C7		Sensor system of swing flap motor error
41	C8		Sensor system of over-current of AC input
42	C9		Suction air thermistor error
43	CA		Discharge air thermistor system error
44	CH		Contamination sensor error
45	CC		Humidity sensor error
46	CJ		Remote control thermistor error
47	CE		Radiation sensor error
48	CF		High pressure switch sensor
49	E0		Outdoor Unit
50	E1	Outdoor unit PCB assembly failure	
52	E3	High pressure switch (HPS) activated	
53	E4	Low pressure switch (LPS) activated	
54	E5	Overload of inverter compressor motor	
55	E6	Over current of STD compressor motor	
56	E7	Overload of fan motor / Over current of fan motor	
57	E8	Over current of AC input	
58	E9	Electronic expansion valve drive error	
59	EA	Four-way valve error	
60	EH	Pump motor over current	
61	EC	Water temperature abnormal	
62	EJ	(Site installed) Protection device activated	
63	EE	Malfunctions in a drain water	
64	EF	Ice thermal storage unit error	
65	H0	Malfunctions in a sensor system	
66	H1	Air temperature thermistor error	
67	H2	Sensor system of power supply error	
68	H3	High Pressure switch is faulty	
69	H4	Low pressure switch is faulty	
70	H5	Compressor motor overload sensor is abnormal	
71	H6	Compressor motor over current sensor is abnormal	
72	H7	Overload or over current sensor of fan motor is abnormal	

73	H8		Sensor system of over-current of AC input
74	H9		Outdoor air thermistor system error
75	HA		Discharge air thermistor system error
76	HH		Pump motor sensor system of over current is abnormal
77	HC		Water temperature sensor system error
79	HE		Sensor system of drain water is abnormal
80	HF		Ice thermal storage unit error (alarm)
81	F0		No.1 and No.2 common protection device operates.
82	F1		No.1 protection device operates.
83	F2		No.2 protection device operates
84	F3		Discharge pipe temperature is abnormal
87	F6		Temperature of heat exchanger(1) abnormal
91	FA		Discharge pressure abnormal
92	FH		Oil temperature is abnormally high
93	FC		Suction pressure abnormal
95	FE		Oil pressure abnormal
96	FF		Oil level abnormal
97	J0		Sensor system error of refrigerant temperature
98	J1		Pressure sensor error
99	J2		Current sensor error
100	J3		Discharge pipe thermistor system error
101	J4		Low pressure equivalent saturated temperature sensor system error
102	J5		Suction pipe thermistor system error
103	J6		Heat exchanger(1) thermistor system error
104	J7		Heat exchanger(2) thermistor system error
105	J8		Oil equalizer pipe or liquid pipe thermistor system error
106	J9		Double tube heat exchanger outlet or gas pipe thermistor system error
107	JA		Discharge pipe pressure sensor error
108	JH		Oil temperature sensor error
109	JC		Suction pipe pressure sensor error
111	JE		Oil pressure sensor error
112	JF		Oil level sensor error
113	L0		Inverter system error
116	L3		Temperature rise in a switch box
117	L4		Radiation fin (power transistor) temperature is too high
118	L5		Compressor motor grounded or short circuit, inverter PCB fault
119	L6		Compressor motor grounded or short circuit, inverter PCB fault
120	L7		Over current of all inputs
121	L8		Compressor over current, compressor motor wire cut
122	L9		Stall prevention error (start-up error) Compressor locked, etc.
123	LA		Power transistor error
125	LC		Communication error between inverter and outdoor control unit
129	P0		Shortage of refrigerant (thermal storage unit)
130	P1		Power voltage imbalance, open phase
132	P3		Sensor error of temperature rise in a switch box
133	P4		Radiation fin temperature sensor error
134	P5		DC current sensor system error
135	P6		AC or DC output current sensor system error
136	P7		Total input current sensor error
142	PJ		Capacity setting error (outdoor)
145	U0	System	Low pressure drop due to insufficient refrigerant or electronic expansion valve error, etc.
146	U1		Reverse phase, Open phase
147	U2		Power voltage failure / Instantaneous power failure
148	U3		Failure to carry out check operation, transmission error
149	U4		Communication error between indoor unit and outdoor unit, communication error between outdoor unit and BS unit
150	U5		Communication error between remote control and indoor unit / Remote control board failure or setting error for remote control
151	U6		Communication error between indoor units

152	U7		Communication error between outdoor units / Communication error between outdoor unit and ice thermal storage unit
153	U8		Communication error between main and sub remote controllers (sub remote control error) / Combination error of other indoor unit / remote control in the same system (model)
154	U9		Communication error between other indoor unit and outdoor unit in the same system / Communication error between other BS unit and indoor/outdoor unit
155	UA		Combination error of indoor/BS/outdoor unit (model, quantity, etc.), setting error of spare parts PCB when replaced
156	UH		Improper connection of transmission wiring between outdoor and outdoor unit outside control adaptor
157	UC		Centralized address duplicated
158	UJ		Attached equipment transmission error
159	UE		Communication error between indoor unit and centralized control device
160	UF		Failure to carry out check operation Indoor-outdoor, outdoor-outdoor communication error, etc.
209	60	Others	All system error
210	61		PC board error
211	62		Ozone density abnormal
212	63		Contamination sensor error
213	64		Indoor air thermistor system error
214	65		Outdoor air thermistor system error
217	68		HVU error (Ventiair dust-collecting unit)
219	6A		Dumper system error
220	6H		Door switch error
221	6C		Replace the humidity element
222	6J		Replace the high efficiency filter
223	6E		Replace the deodorization catalyst
224	6F		Simplified remote controller error
226	51		Fan motor of supply air over current or overload
227	52		Fan motor of return air over current / Fan motor of return air overload
228	53		Inverter system error (supply air side)
229	54		Inverter system error (return air side)
241	40		Humidifying valve error
242	41		Chilled water valve error
243	42		Hot water valve error
244	43		Heat exchanger of chilled water error
245	44		Heat exchanger of hot water error
258	31		The humidity sensor of return air sensor
259	32		Outdoor air humidity sensor error
260	33		Supply air temperature sensor error
261	34		Return air temperature sensor error
262	35		Outdoor air temperature sensor error
263	36		Remote controller temperature sensor error
267	3A		Water leakage sensor 1 error
268	3H		Water leakage sensor 2 error
269	3C		Dew condensation error
339	M2	Centralized remote controller PCB error	
345	M8	Communication error between centralized remote control devices	
347	MA	Centralized remote control devices inappropriate combination	
349	MC	Centralized remote controller address setting error	
65535	N/A	DK-AC-MBS-1	Error in the communication of DK-AC-MBS-1 device with the AC unit



In case you detect an error code not listed, contact your nearest Daikin technical support service.